



Quality of life since 1825

Ducentic Vanity 80cm, 2 drawers

Brown oak

Product features

MOISTURE
RESISTANT



SOFT CLOSE
FURNITURE



- Created for Gustavsberg's 200th anniversary and celebrates the heritage of craftsmanship and design
- Spacious drawer space without the need for a recess for the water trap providing more space for storage
- Soft-closing drawer with full pull-out provides a complete overview of the contents

Article numbers

Art-no.
GB71DCVUD80AW00

EAN
7391530093147

Packaging information

Length: 820 mm | Width: 510 mm | Height: 615 mm

Weight: 34.2 kg

Weight: 1 pc

Assembling & Care

Energy labeling and certifications

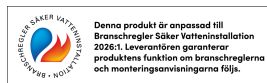
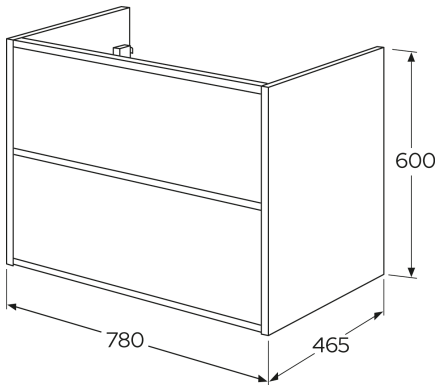

Denna produkt är anpassad till
Branschregler Säker Vatteninstallation
2025:1. Leverantören garanterar
produktens funktion om branschreglerna
och monteringsanvisningarna följs.