



Quality of life since 1825

Ducentic Vanity 60cm, 2 drawers

Light oak, Stone worktop with 1 basin, Grey stone, for 1 double hole tap

Product features

MOISTURE
RESISTANT



SOFT CLOSE
FURNITURE



- Created for Gustavsberg's 200th anniversary and celebrates the heritage of craftsmanship and design
- Spacious drawer space without the need for a recess for the water trap providing more space for storage
- Soft-closing drawer with full pull-out provides a complete overview of the contents

Article numbers

Art-no.

GB71DCVUD60ARSG12

EAN

7391530093505

Packaging information

Length: 630 mm | Width: 510 mm | Height: 835 mm

Weight: 53 kg

Weight: 1 pc

Assembling & Care

Energy labeling and certifications

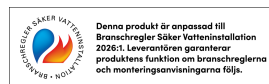
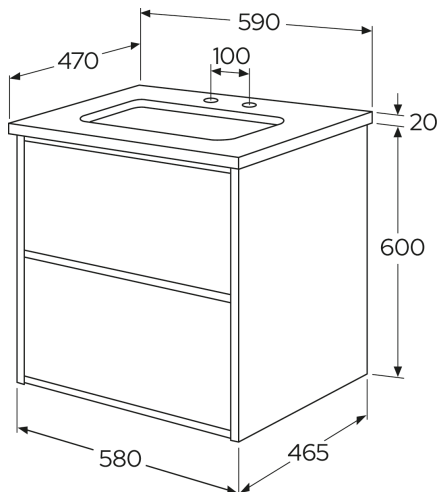

Denne produkt är anpassad till
Branschregler Säker Vätterinstallation
2026:1. Leverantören garanterar
produktens funktion om branschreglerna
och monteringsanvisningarna följs.